

# CERBERUS MANUAL

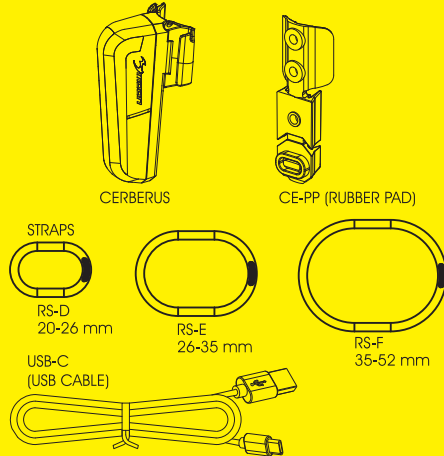

The light is locked for shipment, refer to OPERATION instruction to unlock.  
Read this manual carefully before using and keep for future reference. Visit [www.moon-sport.com](http://www.moon-sport.com) for manual updates.

## CONTENTS



## OPERATION



ON / OFF : Press 1s

MODE SELECT : Click

STEADY / FLASH : Double Click

LOCK/UNLOCK : 1. Power off

2. Press 8s: Locked



\* Lock system: Lock the light to prevent accidentally turned on.

\* Mode memory: The light resumes previous mode upon next usage.

## VARIABLE LUMEN SYSTEM

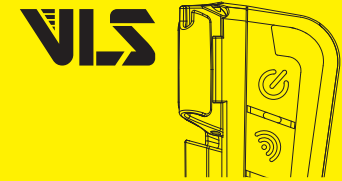

1. Select desired mode.
2. Press and hold to set lumen.
3. Release when reaching desired lumen.

\* Light flashes once when reaching the MAX or MIN lumen level.



\* Restore default mode:

Press +



## RUNTIME

	ANSI FL1	MODE1	MODE2	FLASH	STEADY FLASH	DAY FLASH
DEFAULT LUMEN						
LUMEN		25	50	25	25	150
H:MIN		3:30	1:45	20:15	13:45	19:00
VLS LUMEN						
LUMEN		50-5	50-5	100-10	100-10	150-10
H:MIN		1:45-18:15	1:45-18:15	5:00-44:15	6:15-17:15	19:00-140:00

## AUTO SAFE MODE



To preserve battery when power is low, the light will enter safe mode with less light output for extra **45mins**. Safe mode cannot be override. Recharge battery for maximum performance.

## MOUNTING

RUBBER PAD INSTALLATION

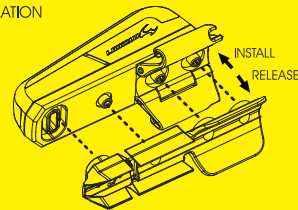

SEATPOST MOUNTING

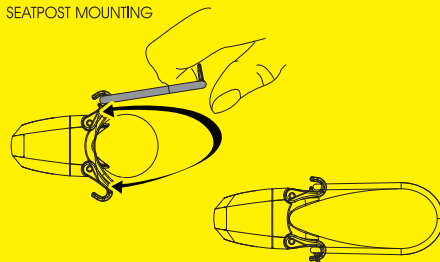

## CHARGING

INDICATOR



CHARGING

1. Power off
2. Plug USB cable to USB port
3. Unplug after fully charged

\* Do not charge over 5V.

\* Keep away from flammable objects while charging.

INDICATOR



## WARNING

Understand country lighting laws and regulations before use.  
Do not shine light directly into eyes.  
Do not mount near wireless computer.  
Do not blind the oncoming vehicles. Always adjust the angle downward.  
Do not submerge the light into water.  
Keep light in cool and dry place when storing.  
Fully recharge the light at least every 3 months during storage.

## WARRANTY

MOON lights are covered by a ONE YEAR LIMITED WARRANTY while MOON batteries are covered by 120 days warranty from the date of purchase. This warranty covers the defects in material and workmanship only with proof of purchase. Please contact original dealer for warranty service. For lights bought on MOON website, please contact [cs@moon-sport.com](mailto:cs@moon-sport.com) for help.

ONLINE WARRANTY REGISTRATION

Visit [www.moon-sport.com](http://www.moon-sport.com) for online warranty registration.